

REVISIONS			
REV	DESCRIPTION	DATE	APPROVED
--	--	--	--

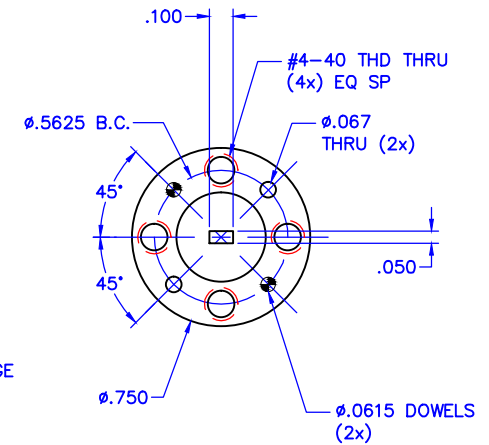
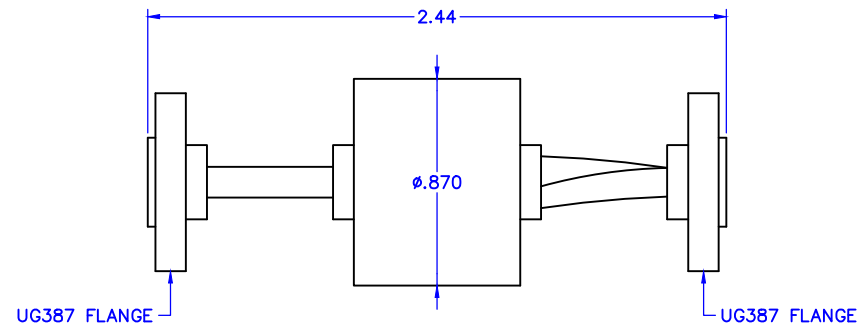
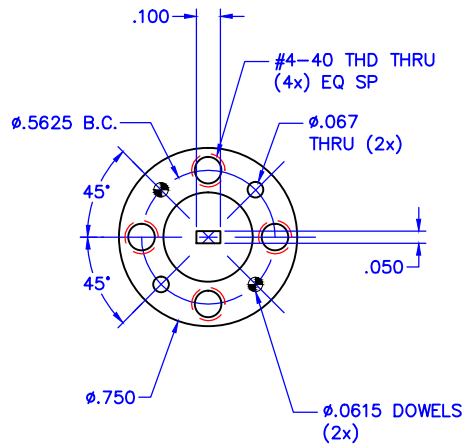

QTY	PART NUMBER	OUTLINE		ITEM
		DESCRIPTION		
	UNLESS OTHERWISE SPECIFIED ALL SURFACES .32/	THIRD ANGLE PROJECTION		Mi-Wave Millimeter Products Inc.
	DIMENSIONS ARE IN INCHES TOLERANCES ARE: DECIMALS: .1234 +/- .0005 .123 +/- .005 .12 +/- .01 ANGLES: +/- .5 DEGREES ALL THREADS TO BE 2A OR 2B			TITLE 115W OUTLINE
	REF DWG# --	DRAFTING: MRN	DATE: 2/23/2012	
		APPROVED: M.S.		
		SHEET NO. 1	OF 1	SIZE A
				DWG NO 21720